

WP10A SELF PRIMING PORTABLE PUMP

INSTALLATION AND OPERATING INSTRUCTIONS



GENERAL

These instructions are to be read in conjunction with the engine instructions.

Two stroke engines power the BIANCO Self Priming Engine Driven Pump model WP10A, which runs on a **mixture of 25 parts unleaded petrol to 1 part two-stroke engine oil.**

Prime the pump with water before operation.



POSITIONING

The Self Priming Engine Driven Pump should be operated outdoors on a level and horizontal surface as close as practical to the water source.



HOSES

Suction hoses should be fitted with a strainer to exclude particles that may damage or block the pump, and be no smaller than the suction connection on the pump. Minimum suction hose inside diameter is 25mm (1") for WP10A.

Suction hoses should be of reinforced, non-collapsible construction, and there should be a continuous rise in the suction hose from the water source to the pump so that air pockets do not form causing suction problems.

Delivery pipe should be suitable for the pressures developed by the pump.

All connections should be air tight for correct priming and operation, and all nuts and tails should have their appropriate washers.



PRIMING

The pump needs to be primed for correct operation.

To prime the pump, firstly, the pump body should be filled with water before starting the engine. Then start the engine with the pump discharge open and run the engine until the pump is pumping normally.

The pump will prime more rapidly at higher speeds, and priming may take up to 3 minutes for long or deep suction.

If the pump fails to prime, then check the following:

- Ensure there are no air leaks in the suction pipe or fittings
- Ensure that the suction hose is not blocked or sitting in mud
- Ensure that the pump suction flap valve is seating properly





SELF PRIMING ENGINE DRIVEN PUMPS OPERATION

The Self Priming Engine Driven Pump should not be allowed to run dry, as damage caused by running with insufficient water is not covered by the warranty.

It is not recommended that the Self Priming Engine Driven Pump model WP10A be operated at speeds in excess of 6500 rpm for extended periods, as operation at full throttle will shorten engine life. For continuous operation the throttle should be set at approximately $\frac{3}{4}$ open which corresponds to approximately 5000 rpm.

The Self Priming Engine Driven Pump should not pump water containing abrasive materials such as sand, dirt etc., or water containing salt, chemicals or hydrocarbons as the pump will suffer seal failure and wear which is not covered by the warranty.

The Self Priming Engine Driven Pump should be drained after use, and if the Self Priming Engine Driven Pump is to be stored, then the pump should be run until all the fuel is used, then the water drained, and placed in a dry place.

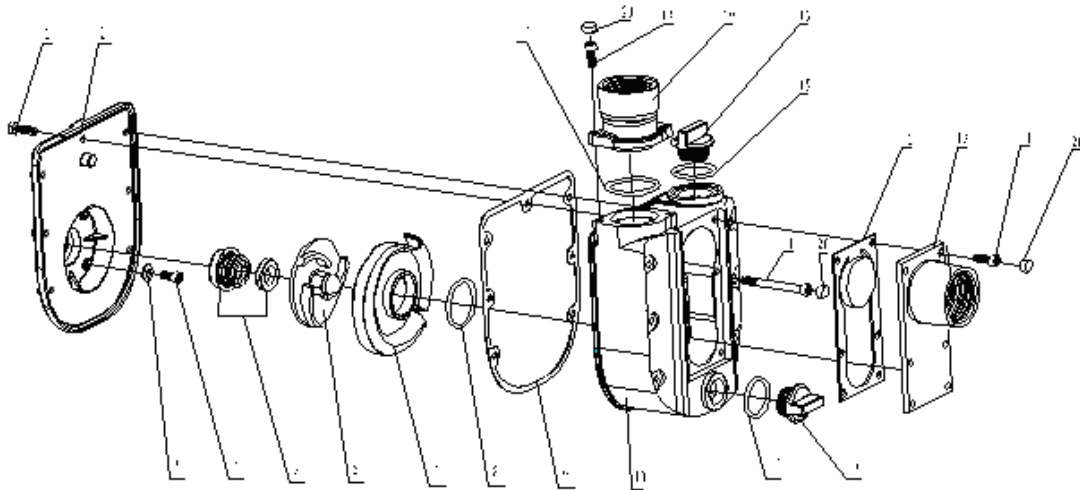

| NO. | Name | Quantity | NO. | Name | Quantity |
|-----|-----------------|----------|-----|-----------------|----------|
| 1 | Hexangular bolt | 1 | 11 | Bolt | 6 |
| 2 | Pump cover | 1 | 12 | Check valve | 1 |
| 3 | Nylon washer | 4 | 13 | Inlet flange | 1 |
| 4 | Hexangular bolt | 4 | 14 | Bolt | 6 |
| 5 | Mechanical seal | 1 | 15 | O-ring | 2 |
| 6 | Impeller | 1 | 16 | Whorl Plug | 2 |
| 7 | Diffuser | 1 | 17 | O-ring | 1 |
| 8 | O-ring | 1 | 18 | Hexangular bolt | 2 |
| 9 | Sealed washer | 1 | 19 | Outlet flange | 1 |
| 10 | Pump body | 1 | 20 | Plastic cover | 14 |



Distributed by
WHITE INTERNATIONAL PTY LTD A.B.N. 48 000 119 380
 52-60 Ashford Ave, Milperra NSW 2214 Ph 02 9783 6000 Fax 02 9783 6001

WP10A11/07/06

CUSTOMER SERVICE HOTLINE 1300 783 601 CUSTOMER SERVICE FAXLINE 02 9783 6003



12 MONTHS WARRANTY*

WP10A SELF PRIMING PORTABLE PUMP TERMS & CONDITIONS

(Subject to the provisions of the Trade Practices Act and Goods and Consumer Protection Legislation of various States and New Zealand)

- 1) White International Pty Ltd warrants that the pumps that we distribute, are free from defects in workmanship and materials, for 12 months from the date of purchase. Subject to the conditions of the warranty White International will repair any defective products free of charge at the premises of our authorised service agents throughout Australia and New Zealand.
- 2) This warranty excludes transportation costs to and from White International or its appointed service agents and excludes defects due to non-compliance with installation instructions, neglect or misuse, inadequate protection against freezing, low voltage or use or operation for purposes other than those for which they were designed. For further information regarding the suitability of your intended application contact us on our Sales Hotline.
- 3) The 12 months warranty refers to all BIANCO Pumpz sold after the 1st May 2003, and is not transferable to another BIANCO pump and only applies to the original owner, purchaser or end user, and is subject to the Trade Practises Act and Goods and Consumer Protection legislation of the various states and New Zealand.
- 4) Our warranty commences from the date of purchase of the above mentioned pumps. Proof of purchase is required before consideration under warranty is given. Record your date of purchase in the space below and retain this copy for your records.

Date of Purchase: _____

Model Purchased: _____



WHITE INTERNATIONAL PTY LTD A.C.N. 48 000 119 380
(PO Box 4755, Milperra BC NSW 1891
Ph (02) 9783 6000 Fax (02) 9783 6001
SALES HOTLINE 1300 783 601

WHITE INTERNATIONAL NZ LTD
(PO Box 12704, Penrose)
Ph (09) 579 9777 Fax (09) 579 7775
SALES HOTLINE 0800 509 506